



Technical Details

Style

Rangehood Type:	Undermount
Category Size:	52cm

Functionality

Extraction Type:	Ducted or Recirculating
Extraction Rate:	612m ³ /hr Net 700m ³ /hr Gross
Number of Motors:	1
Watts of Motor:	190w
Speeds:	3
Filtration:	1 x Aluminium Mesh
Lights:	2 x 1.5W LED
dBA Rating:	51-58dBA

Accessories

Charcoal Filter:	Optional (ORCF110)
------------------	--------------------

Installation

Maximum Current:	10amps 3 Pin Plug
Connection:	240V, 50Hz
Installation Type:	Built Into Overhead Cabinetry
Warranty:	24 Months Parts & Labour

Dimensions/Weight

Overall Dimensions (mm):	254(h) x 520(w) x 296(d)
Duct Diameter (mm):	150mm
Weight:	7kg

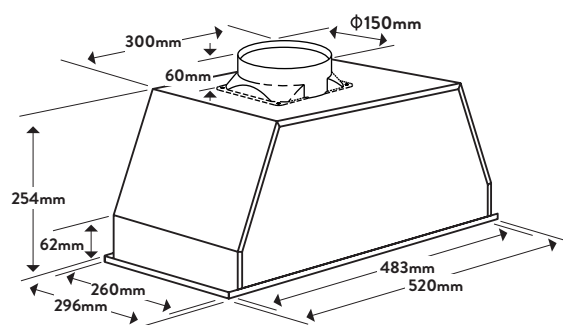

Aesthetics

Finish:	Stainless Steel
Controls:	NA

Key Features



Concealed Design

This rangehood will be concealed and look streamline under cupboards, perfect for smaller kitchens.



Buttonless design

This rangehood should be installed to operate when the cooktop is switched on by a separate switch. This design is great for student accommodation, allowing for correct operation of the product.



LED Light

LED lights use a small amount of energy, generate little heat and last a long time. Not only are they cost effective, they will ensure your cooktop is well lit.

Customer Care

T: 1300 11 4357
E: sales@residentiagroup.com.au

NB: Drawings are not to scale - they are to assist only.
WARNING: technical specifications and product sizes can be varied by the manufacturer without notice. Cutouts for appliances should only be by physical product measurements.
The above information is indicative only.