



omega

Instruction Manual

Ceramic Cooktop

OCC64TCOM

Thank you for purchasing an Omega appliance

Tailored for the modern aesthetic and lifestyle of busy people, your new Omega Appliance will make a welcome addition to the family.

Omega caters to style-savvy customers who look for balance between stunning form and clever function. This means a combination of sleek, chic, sophisticated design yet effortless functionality. And we source from the best. The best craftsmanship. The best innovation. From the best international design-houses.

All brought together under an appliance that stands for design-led balance.

Please take the time to read through the following instruction manual to familiarise yourself with the installation, operation requirements and maintenance to ensure optimum performance.

Further Information

For important information about your Omega Appliance such as warranty registration, manuals, features, and specifications please visit omegaappliances.com.au (if you are in Australia) and omegaappliances.co.nz (if you are in New Zealand) or contact our Customer Care team on the below email or phone numbers.

Registering Your Warranty

For peace of mind you can register your warranty at omegaappliances.com.au. Further information on the Warranty can be found at the end of this manual.

Contact Us

Our customer service team is here to help you with any question or concern. Both teams are on call Monday to Friday 9.00am to 5.00pm and of course you can always send an email at your convenience.

Australia Contact Details

Monday to Friday 9.00am – 5.00pm
Email: support@residentiagroup.com.au
Phone: 1300 11 4357

New Zealand Contact Details

Monday to Friday 9.00am – 5.00pm
Email: customercare@monacocorp.co.nz
Phone: 09 415 6000

To stay up to date and find simple and easy recipes, follow us on our socials:

facebook.com/omegaappliances
instagram.com/omegaappliances_au

READ THE INSTRUCTION BOOKLET BEFORE INSTALLING AND USING THE APPLIANCE.

It is important that you retain these instructions, proof of purchase as well as other important documents about this product for future reference.

The manufacturer will not be responsible for any damage to property or to persons caused by incorrect installation or improper use of the appliance.

Due to continual product development, Omega reserves the right to alter specifications and appearances without notice.

Contents

Important Safety Warnings	4
Appliance Details.....	6
Installation Instructions.....	7
Electrical Connection.....	9
Operating Instructions	10
Maintenance and Cleaning	14
Warranty	16

Disposal Information

- Most of the packaging materials are recyclable. Please dispose of these materials through your local recycling depot or by placing them into appropriate collection containers.
- If you wish to discard this product, please contact your local authorities and ask for the correct method of disposal.

Important Safety Warnings

IMPORTANT: Read the assembly instruction section and safety precautions of this booklet carefully before removing the contents of this carton.

1. This appliance is not intended for use by persons (including children) with reduced physical, sensory or mental capabilities, or lack of experience or knowledge, unless they have been given supervision or instruction concerning the use of the appliance by a person responsible for their safety. Children should be supervised to ensure that they do not play with the appliance.
2. After removing the packaging, make sure to check if there is any damage to the appliance. If there is any damage (including cracked glass), never attempt to use the appliance and immediately contact your Authorized Service Centre. As packaging materials can be dangerous to children, they need to be collected immediately and put out of reach.
3. In certain circumstances electrical appliances may be a danger hazard. Check the conformity of voltage and power settings, which are specified on the information plate attached to the appliance and/or packaging, with the usage conditions available.
4. Danger of fire: Do not place heavy objects in or on these appliances, use for storage or as a cutting surface. This appliance is designed for cooking food only. Use flat based, stable cooking pots only.
5. This appliance is designed for domestic household use only and for the cooking of domestic food products. Use as a commercial appliance will void the warranty. It should not be used in a marine environment or outdoors and must be fully built in. Do not use the appliances until fully installed.
6. A means for disconnection must be incorporated in the fixed wiring in accordance with the wiring rules.
7. The electrical connection must be accessible after installation. The appliance must be electrically isolated before any maintenance can be performed.
8. The appliance is not intended to be operated by means of an external timer or separate remote-control system.
9. Electrical connection must be made as per local wiring rules and regulations. Do not disconnect the appliance with wet hands or bare feet, and do not disconnect the power cord with extreme force.
10. Ensure that the kitchen is well ventilated or mechanical ventilation is in use while cooking on this appliance.
11. Do not store or use flammable materials or aerosols near the cooktop. Items made from aluminum, plastic or plastic film should also be kept away from the appliance, as they may fuse to the surface.
12. **WARNING** – The surface temperature of this appliance exceeds 95°C. To avoid a hazard, under bench access must be restricted. Aboard must be installed underneath the cooktop.
13. **WARNING** - The cooktop will become hot during and directly after use. Do not touch the surface during this time, as it may be hot and can cause burns. To avoid burns, children should be kept away.
14. Cleaning may only be commenced on the appliance once it has cooled down and is turned off. Do not use a steam jet or any other high pressure cleaning equipment to clean the appliance.
15. When the appliance is not being used, turn the appliance off.
16. Where this appliance is installed in a caravan, it shall NOT be used as a space heater.
17. Do not modify this appliance.
18. Do not use harsh abrasive cleaners or sharp metal scrapers to clean the glass surface as they can scratch the surface, which may result in the glass shattering. Clean the glass using a warm damp cloth (e.g., dishcloth) and dry it with a soft dry tea towel.
19. All cabinetry and materials used in the installation must be able to withstand a minimum temperature of 100°C above the ambient temperature of the room it is located in, whilst in use. Certain types of vinyl or laminate kitchen furniture are particularly prone to heat damage or discoloration at temperatures below the guidelines given above. Any damage caused by the appliance being installed without adhering to the temperature limits set out above will be the liability of the owner. To avoid any hazards, limit access to the under-bench section of the cooktop.
20. The appliance must be installed and put into operation by an authorized technician under the conditions provided by the manufacturer in this manual. The manufacturer cannot be held responsible for any damage that might occur due to faulty installation.

omega

Important Safety Warnings

21. Damage can occur to bench tops if pots and pans are allowed to overlap the bench top. This can result in heat being transferred to the bench top. Ensure that correct sized pots & pans are used. Cast iron and cast aluminum cookware with damaged bases may scratch the cooktop surface if they are dragged across it. Pans should be lifted on and off the cooktop surface and not dragged. Cooking zones should not be switched on without cookware placed on it. Also, the cookware should not be empty for any length of time.
22. If any cracking is noticed on the vitro-ceramic cooktop, turn the appliance off immediately to avoid the possibility of electric shock and call your Authorized Service Centre.
23. Do not leave the cooktop while cooking with solid or liquid oils. There may be flaming up in conditions of extreme heating.
24. Never pour water onto the flames occurring from oil. Immediately turn the cooktop off and cover the pan with a lid or fire blanket in order to smother the flame.
25. The ceramic cooker hob must be installed by qualified personnel or technicians. We have professionals at your service. Please never conduct the operation by yourself.
26. The ceramic cooker hob shall not be mounted to cooling equipment, dishwashers and rotary dryers.
27. The ceramic cooker hob shall be installed such that better heat radiation can be ensured to enhance its reliability.
28. The wall and induced heating zone above the work surface shall withstand heat.
29. To avoid any damage, the sandwich layer and adhesive must be resistant to heat.
30. A steam cleaner is not to be used.
31. CAUTION: The cooking process has to be supervised. A short term cooking process has to be supervised continuously.
32. WARNING: Unattended cooking on a hob with fat or oil can be dangerous and may result in a fire.
33. If the supply cord is damaged, it must be replaced by the manufacturer, its service agent or similarly qualified persons in order to avoid a hazard.



- DO NOT** OPERATE THIS APPLIANCE BEFORE READING THE INSTRUCTION BOOKLET.
- DO NOT** PLACE ARTICLES ON OR AGAINST THIS APPLIANCE.
- DO NOT** STORE CHEMICALS OR FLAMMABLE MATERIALS OR SPRAY AEROSOLS NEAR THIS APPLIANCE.
- DO NOT** USE EXTERNAL CONTROLLERS OR TIMERS ON THIS APPLIANCE

Installation Instructions

Cut out the work surface according to the sizes shown in the image below.

Ensure that there is a minimum of 50mm of space around the cut-out.

The thickness of the bench should be at least 30mm. Please select heat-resistant and insulated bench materials (Wood and similar fibrous or hygroscopic materials should not be used as the bench material unless impregnated) to avoid the electrical shock and larger deformation caused by heat radiation from the hotplate.

Note: The safety distance between the sides of the hob and the inner surfaces of the worktop should be at least 3mm.

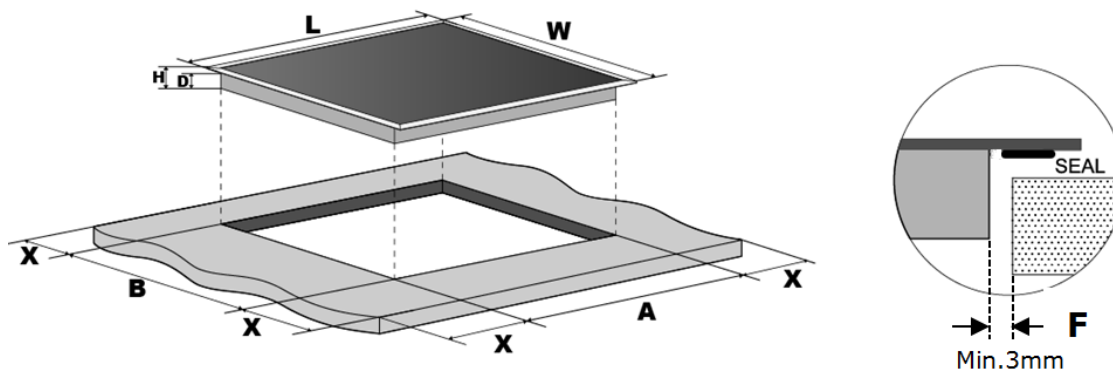

L(mm)	W(mm)	H(mm)	D(mm)	A(mm)	B(mm)	X(mm)	F(mm)
590	520	55	51	560+4 +1	490+4 +1	50 min.	3 min.

Important: Ensure that the cooktop is well ventilated and that the air inlet and outlet are not blocked.

Note: The safety distance between the hotplate and the cupboard above the hotplate should be at least 760mm.

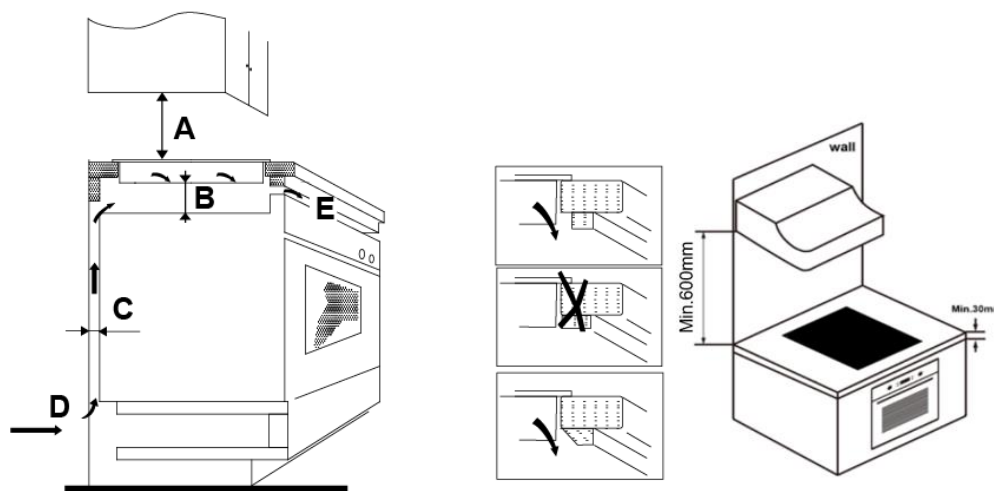

A(mm)	B(mm)	C(mm)	D	E
760	50 min.	20 min.	Air inlet	Air outlet (5mm)

Installation Instructions

In order to avoid accidentally touching the hot underside of the cooktop, or getting an unexpected electric shock, it is necessary to put a wooden insert, fixed by screws, at a minimum distance of 50mm from the bottom of the cooktop.

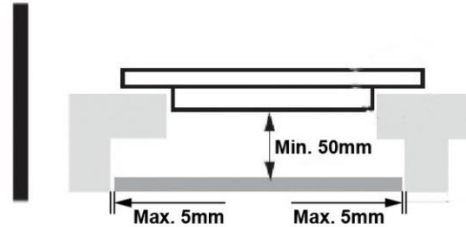

There are ventilation holes around outside of the cooktop. Ensure that these holes are not blocked by the bench when you install the cooktop.

Be aware that any glue used on the bench must be resistant to a minimum temperature of 150°C.

The rear wall, adjacent and surrounding surfaces must therefore be able to withstand a temperature of 90°C.

Before locating the fixing brackets

The unit should be placed on a stable, smooth surface (use the packaging). Do not apply force onto the controls protruding from the hob.

Fix the hob to the bench by screwing the four brackets to the bottom of the cooktop (see image) after installation.

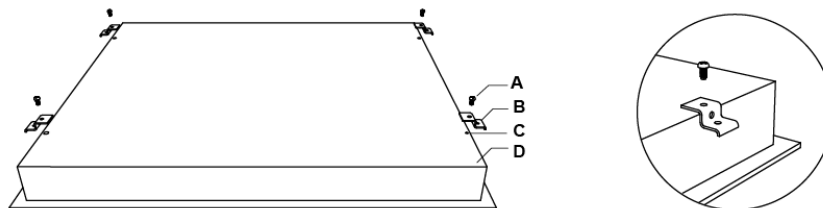

A	B	C	D
Screw	Bracket	Screw hole	Base

Adjust the bracket position to suit for different bench thicknesses.

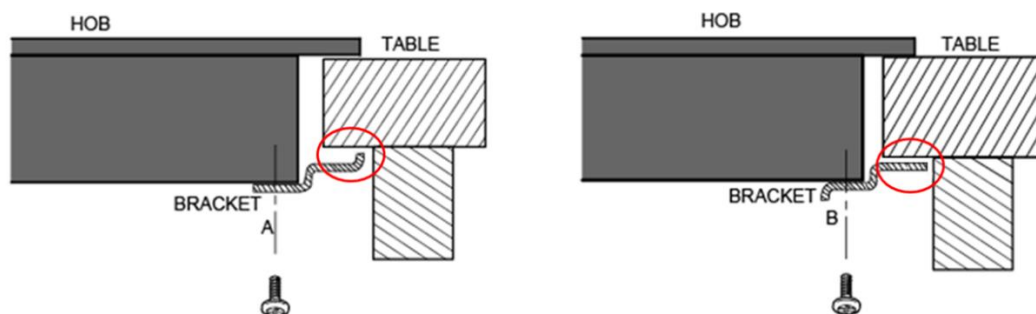

The brackets should not touch the bench after installation (see image above).

Electrical Connection

The power supply should be connected in compliance with the relevant standard, or a single-pole circuit breaker. The method of connection is shown below.

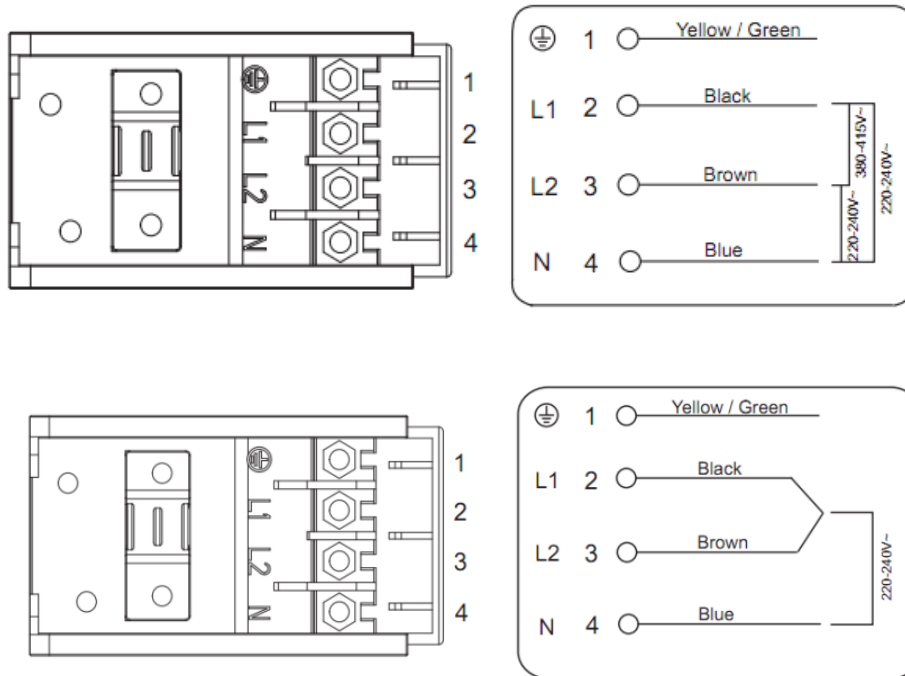

1. If the cable is damaged or needs replacing, this should be done by an after-sales technician using the proper tools, so as to avoid any accidents.
2. If the appliance is being connected directly to the mains supply, an omni polar circuit breaker must be installed with a minimum gap of 3mm between the contacts.
3. The installer must ensure that the correct electrical connection has been made and that it complies with safety regulations.
4. The cable must not be bent or compressed.
5. The cable must be checked regularly and only replaced by a properly qualified person.

Operating Instructions

Touch Controls

- The controls respond to touch, so you don't need to apply any pressure.
- Use the pad of your finger, not the tip.
- You will hear a beep each time a touch is registered.
- Make sure the controls are always clean, dry, and that there are no objects (e.g. a utensil or a cloth) covering them. Even a thin film of water may make the controls difficult to operate.

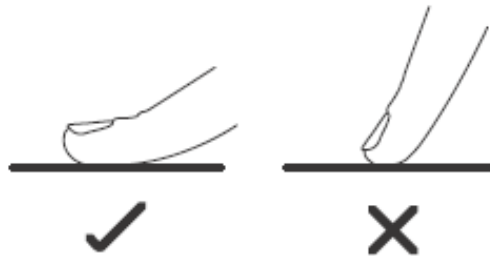

Choosing the Right Cookware

Do not use cookware with jagged edges or a curved base.



Make sure that the base of your pan is smooth, sits flat against the glass, and is the same size as the cooking zone. Always centre your pan on the cooking zone.

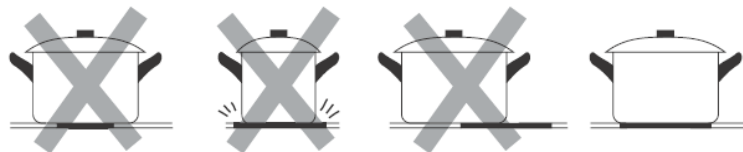

Always lift pans off the ceramic hob – do not slide, or they may scratch the glass.

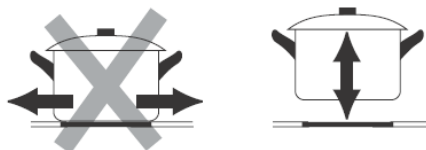

Operating Instructions

Using the Cooktop

When the power is connected you will hear a beep and all the lights will come on for one second and then go out. This indicates that the cooktop has entered standby mode.

Turn the cooktop on by touching the  On / Off button. All indicators will show “-“.



Place a suitable pan on the cooking zone that you wish to use. Make sure that the bottom of the pan and the surface of the cooking zone are clean and dry.

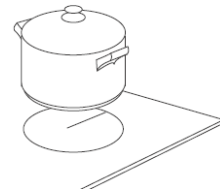

Select a heat setting by touching the “+” or “-” buttons. You can modify the heat setting at any time during cooking. By holding down either of these buttons, the value will adjust up or down.



Note: If you don't choose a heat setting within one minute, the ceramic hob will automatically switch off.

Turn the cooking zone off by scrolling down to “0” or touching the “+” and “-” buttons together.



Turn the whole cooktop off by touching the  On/Off button.



Beware of hot surfaces

“H” will indicate which cooking zone is hot to touch. It will disappear when the surface has cooled down to a safe temperature.

Safety Lock

The controls can be locked to prevent accidental use and to protect children. When the controls are locked, all buttons except for the On/Off button are disabled.

- To lock the controls, press the  lock button. The timer indicator will display “Lo”.
- To unlock the controls, press and hold the  lock button while the cooktop is turned on.

Operating Instructions

Using the Timer

The timer can be used in two different ways:

- You can use it as an alarm. In this case it will not turn any cooking zones off.
- You can use it to automatically turn off a cooking zone after the timer has finished.

The timer can be set to a maximum of 99 minutes.

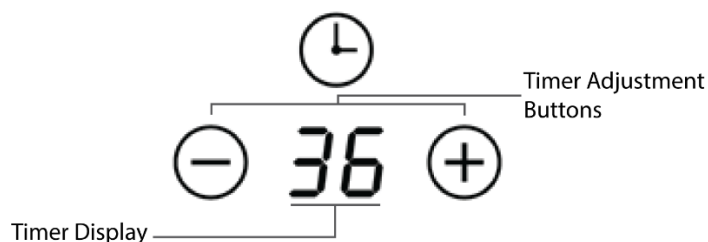

Using the Timer as an Alarm

Adjust the timer with the “+” and “-” buttons. The timer display will start flashing.

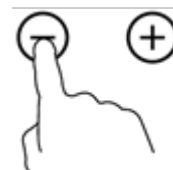

When the time is set, the timer will begin counting down immediately. The display will show the remaining time and the timer indicator will flash for five seconds.

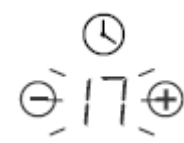

To cancel the timer, hold the “+” and “-” buttons together. The display will change to “--”.

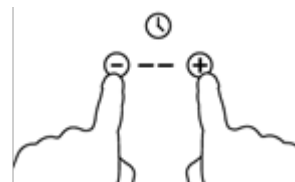

Once the timer has elapsed, the buzzer will sound for 30 seconds. The display will change to “--”.



Hint:

- Touch the “+” or “-” buttons once to change the timer by one minute.
- Touch and hold the “+” or “-” buttons to change the timer by ten minutes.
- If the setting exceeds 99 minutes, the timer will automatically return to 0 minutes.

Operating Instructions

Setting the Timer to turn one or more Cooking Zones Off

Touch the “+” or “-” button of the cooking zone you wish to set the timer for.

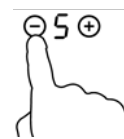

Set the timer as described on the previous page.



A red dot next to the power level for the corresponding cooking zone will illuminate to indicate that the timer has been set for it.

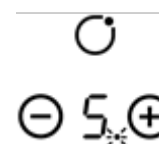

When the timer has elapsed the corresponding cooking zone will switch off automatically. The cooking zone display will show “H” which means that it is still hot.

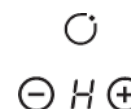

Note: If you wish to change the timer once it has been set, you need to start from the beginning.

Multiple Timers

If more than one cooking zone is using the automatic timer function, the timer display will show the shortest time remaining. The red dot next to the power indicator will flash to show to currently displayed timer.

When the shortest timer has elapsed, the corresponding the display will show the next shortest time.

Over-Temperature Protection

This cooktop is equipped with a temperature sensor which can detect when the cooktop is at an excessive heat. If this happens, the sensor will automatically switch off a cooking zone.

Residual Heat Warning

When a cooking zone is switched off but still hot, its display will show “H” to indicate that it is still hot.

Default Working Times

In the event that you forget to turn off a cooking zone, there is an automatic shut off safety feature that will automatically turn the cooking zone off after a period of time. See the table below for the working times.

Power level	1	2	3	4	5	6	7	8	9
Default working timer (hour)	8	8	8	4	4	4	2	2	2

Maintenance and Cleaning

Cleaning

Problem	Resolution	Important
Everyday soiling on glass (fingerprints, marks, stains left by food or non-sugary spill overs on the glass)	<ol style="list-style-type: none"> 1. Switch the power to the cooktop off. 2. Apply a cooktop cleaner while the glass is still warm (but not hot!) 3. Rinse and wipe dry with a clean cloth or paper towel. 4. Switch the power to the cooktop back on. 	<ul style="list-style-type: none"> • When the power to the cooktop is switched off, there will be no 'hot surface' indication but the cooking zone may still be hot! Take extreme care. • Heavy-duty scourers, some nylon scourers and harsh/abrasive cleaning agents may scratch the glass. Always read the label to check if your cleaner or scourer is suitable. • Never leave cleaning residue on the cooktop: the glass may become stained.
Boil-overs, melts, and hot sugary spills on the glass	<p>Remove these immediately with a fish slice, palette knife or razor blade scraper suitable for Ceramic glass cooktops, but beware of hot cooking zone surfaces:</p> <ol style="list-style-type: none"> 1. Switch the power to the cooktop off at the wall. 2. Hold the blade or utensil at a 30° angle and scrape the soiling or spill to a cool area of the cooktop. 3. Clean the soiling or spill up with a dish cloth or paper towel. 4. Follow steps 2 to 4 for 'Everyday soiling on glass' above. 	<ul style="list-style-type: none"> • Remove stains left by melts and sugary food or spill overs as soon as possible. If left to cool on the glass, they may be difficult to remove or even permanently damage the glass surface. • Cut hazard: when the safety cover is retracted, the blade in a scraper is razor-sharp. Use with extreme care and always store safely and out of reach of children.
Spill overs on the touch controls	<ol style="list-style-type: none"> 1. Switch the power to the cooktop off. 2. Soak up the spill 3. Wipe the touch control area with a clean damp sponge or cloth. 4. Wipe the area completely dry with a paper towel. 5. Switch the power to the cooktop back on. 	<ul style="list-style-type: none"> • The cooktop may beep and turn itself off, and the touch controls may not function while there is liquid on them. Make sure you wipe the touch control area dry before turning the cooktop back on.

Troubleshooting

Problem	Possible causes	What to do
The cooktop cannot be turned on.	No power.	Make sure the ceramic hob is connected to the power supply and that it is switched on. Check whether there is a power outage in your home or area. If you've checked everything and the problem persists, call a qualified technician.
The touch controls are unresponsive.	The controls are locked.	Unlock the controls. See section 'Operating Instructions' for instructions.
The touch controls are difficult to operate.	There may be a slight film of water over the controls or you may be using the tip of your finger when touching the controls.	Make sure the touch control area is dry and use the ball of your finger when touching the controls.
The glass is being scratched.	<ul style="list-style-type: none"> • Rough-edged cookware. • Unsuitable, abrasive scourer or cleaning products being used. 	Use cookware with flat and smooth bases. See 'Choosing the Right Cookware'.
Some pans make crackling or clicking noises.	This may be caused by the construction of your cookware (layers of different metals contracting and expanding differently).	This is normal for cookware and does not indicate a fault.

Warranty

WARRANTY TERMS AND CONDITIONS COOKTOPS

This document sets out the terms and conditions of the product warranties for Residentia Group Appliances. It is an important document. Please keep it with your proof of purchase documents in a safe place for future reference should you require service for your Appliance.

1. IN THIS WARRANTY

- (a) 'acceptable quality' as referred to in clause 10 of this warranty has the same meaning referred to in the ACL;
 - (b) 'ACL' means Trade Practices Amendment (Australian Consumer Law) Act (No.2) 2010;
 - (c) 'Appliance' means any Residentia Group product purchased by you accompanied by this document;
 - (d) 'ASR' means Residentia Group authorised service representative;
 - (e) 'Residentia Group' means Residentia Group Pty Ltd of 165 Barkly Ave, Burnley VIC 3121, ACN 600 546 656 in respect of Appliances purchased in Australia;
 - (f) 'major failure' as referred to in clause 10 of this warranty has the same meaning referred to in the ACL and includes a situation when an Appliance cannot be repaired or it is uneconomic for Residentia Group, at its discretion, to repair an Appliance during the Warranty Period;
 - (g) 'Warranty Period' means:
 - (i) where the Appliance is used for personal, domestic or household use (i.e. normal single family use) as set out in the instruction manual, the Appliance is warranted against manufacturing defects for 24 months, following the date of original purchase of the Appliance;
 - (h) 'you' means the purchaser of the Appliance not having purchased the Appliance for re-sale, and 'your' has a corresponding meaning.
2. This warranty only applies to Appliances purchased and used in Australia and is in addition to (and does not exclude, restrict, or modify in any way) any non-excludable statutory warranties in Australia.

3. During the Warranty Period Residentia Group or its ASR will, at no extra charge if your Appliance is readily accessible for service, without special equipment and subject to these terms and conditions, repair or replace any parts which it considers to be defective. Residentia Group or its ASR may use remanufactured parts to repair your Appliance. You agree that any replaced Appliances or parts become the property of Residentia Group. This warranty does not apply to light globes, batteries, filters, seals or similar perishable parts.
4. Parts and Appliances not supplied by Residentia Group are not covered by this warranty.
5. You will bear the cost of transportation, travel and delivery of the Appliance to and from Residentia Group or its ASR. If you reside outside of the service area, you will bear the cost of:
 - (a) travel of an authorised representative;
 - (b) transportation and delivery of the Appliance to and from Residentia Group or its ASR, in all instances, unless the Appliance is transported by Residentia Group or its ASR, the Appliance is transported at the owner's cost and risk while in transit to and from Residentia Group or its ASR.
6. Proof of purchase is required before you can make a claim under this warranty.
7. You may not make a claim under this warranty unless the defect claimed is due to faulty or defective parts or workmanship. Residentia Group is not liable in the following situations (which are not exhaustive):
 - (a) the Appliance is damaged by:
 - (i) accident
 - (ii) misuse or abuse, including failure to properly maintain or service
 - (iii) normal wear and tear
 - (iv) power surges, electrical storm damage or incorrect power supply
 - (v) incomplete or improper installation
 - (vi) incorrect, improper or inappropriate operation
 - (vii) insect or vermin infestation
 - (viii) failure to comply with any additional instructions supplied with the Appliance;

— THIS WARRANTY IS VALID IN AUSTRALIA ONLY —

Warranty

- (b) the Appliance is modified without authority from Residentia Group in writing;
 - (c) the Appliance's serial number or warranty seal has been removed or defaced;
 - (d) the Appliance was serviced or repaired by anyone other than Residentia Group, an authorised repairer or ASR.
8. This warranty, the contract to which it relates and the relationship between you and Residentia Group are governed by the law applicable where the Appliance was purchased.
9. To the extent permitted by law, Residentia Group excludes all warranties and liabilities (other than as contained in this document) including liability for any loss or damage whether direct or indirect arising from your purchase, use or non use of the Appliance.
10. For Appliances and services provided by Residentia Group in Australia, the Appliances come with a guarantee by Residentia Group that cannot be excluded under the Australian Consumer Law. You are entitled to a replacement or refund for a major failure and for compensation for any other reasonably foreseeable loss or damage. You are also entitled to have the Appliance repaired or replaced if the Appliance fails to be of acceptable quality and the failure does not amount to a major failure. The benefits to you given by this warranty are in addition to your other rights and remedies under a law in relation to the Appliances or services to which the warranty relates.
11. At all times during the Warranty Period, Residentia Group shall, at its discretion, determine whether repair, replacement or refund will apply if an Appliance has a valid warranty claim applicable to it.
12. Missing parts are not covered by warranty. Residentia Group reserves the right to assess each request for missing parts in a case by case basis. Any parts that are not reported missing in the first week after purchase will not provide free of charge.
13. To enquire about claiming under this warranty, please follow these steps:
- (a) carefully check the operating instructions, user manual and the terms of this warranty;
 - (b) have the model and serial number of the Appliance available;
 - (c) have the proof of purchase (e.g. an invoice) available;
 - (d) telephone the numbers shown below.
14. You accept that if you make a warranty claim, Residentia Group and its ASR may exchange information in relation to you to enable Residentia Group to meet its obligations under this warranty.

IMPORTANT

Before calling for service, please ensure that the steps in point 13 have been followed.

CONTACT SERVICE

→ Service: 1300 11 HELP (4357)

The Australian Consumer Law requires the inclusion of the following statement with this warranty:

Our goods come with guarantees that cannot be excluded under the Australian Consumer Law. You are entitled to a replacement or refund for a major failure and for compensation for any other reasonably foreseeable loss or damage. You are also entitled to have the goods repaired or replaced if the goods fail to be of acceptable quality and the failure does not amount to a major failure.

— THIS WARRANTY IS VALID IN AUSTRALIA ONLY —

