

# 28L Built-in Microwave

MODEL / IMC28BF

## FEATURES

28L capacity  
5 power levels  
Frameless black glass  
95 minute cooking timer  
Defrost by weight & time  
8 automatic cooking functions  
Rotary knob & button controls  
White LED digital display  
Stainless steel interior cavity  
315mm turntable plate  
Child safety lock  
Quick start

## 8 AUTO MENU PROGRAMS

> Pizza  
> Meat  
> Vegetable  
> Pasta  
> Potato  
> Fish  
> Beverage  
> Popcorn

## RATED POWER

Rated Voltage:

220-240V, 50Hz

Rated Input Power:

1450W

Rated Output Power:

900W

## SAFETY

Child Lock function

## REQUIREMENTS

Supplied with a 10 amp plug

## PRODUCT DIMENSIONS

Packaged (w, d, h mm):

653 × 500 × 466mm

Physical (w, d, h mm):

595 × 410 × 388mm

Cut-out (w, d, h mm):

600 × 600 min. × 390mm

Weight (net/gross):

16.9kg/19.5kg

## INSTALLATION

Under-bench or wall tower

See below diagram



ALL INALTO PRODUCTS COME WITH A 2 YEAR WARRANTY. AUSTRALIAN CUSTOMERS ARE ELIGIBLE TO RECEIVE 1 EXTRA YEAR FOR FREE, SIMPLY REGISTER ONLINE WITHIN 90 DAYS OF PURCHASE

[WWW.INALTO.HOUSE/REGISTRATION](http://WWW.INALTO.HOUSE/REGISTRATION)



**Ventilation: Option 1**  
Cutout 45mm × 500mm  
top rear of cabinet

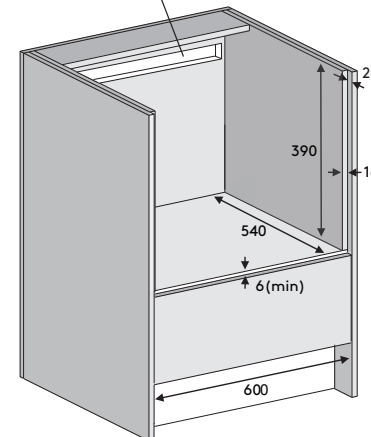

**Ventilation: Option 2**  
140mm × cabinet width vented  
down into kick panel space

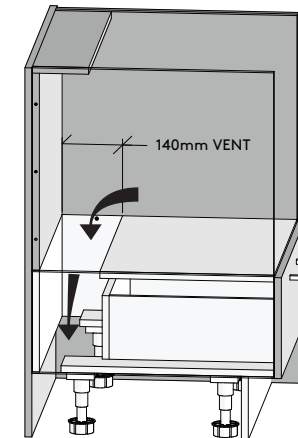

**Ventilation: Option 3**  
(Tower Installation)  
45mm × cabinet width  
vented into roof cavity  
or top of cabinetry

